



SOHO



EMERGENCY



E-MEDICAL



INDUSTRY



DATACENTRE



TRANSPORT

# Sentinel Dual SDH



ONLINE



Tower Rack



USB plug



Plug & Play installation



Hot swap battery



Energy Share



**1:1** 1-3 kVA

## HIGHLIGHTS

- **Power factor 0.9**
- **Simplified installation**
- **Installation versatility**
- **Reduced running costs**
- **Runtime expandability**
- **Low noise level**

Sentinel Dual is the new range of high density double conversion ON LINE UPS suitable for powering a wide range of devices such as servers, storage systems, VoIP telephony equipment, network and medical systems as well as industrial applications.

It is also ideal for powering and protecting Blade Server systems with high input power factor. At only 2U, Sentinel Dual is ideal for 19" rack cabinet installations. Sentinel Dual has a practical, modern design and includes several performance advantages over traditional ON LINE UPS. All developed by the Riello UPS research and development team. The newly-designed inverter is one of the best energy conversion systems on the market, with a 0.9 output power

factor and 92% operating efficiency in ON LINE Mode. For business continuity applications requiring long battery runtimes, battery autonomy can be extended up to several hours using ER models fitted with more powerful battery chargers. With energy savings in mind, Sentinel Dual is also fitted with a shut-off button to reduce energy consumption to zero during prolonged periods of inactivity.

### SIMPLIFIED INSTALLATION

- Sentinel Dual can be installed as a tower or in 19" rack cabinets, by simply pulling out and rotating the display panel;
- Low noise (<40 dBA): can be installed in any environment thanks to its high

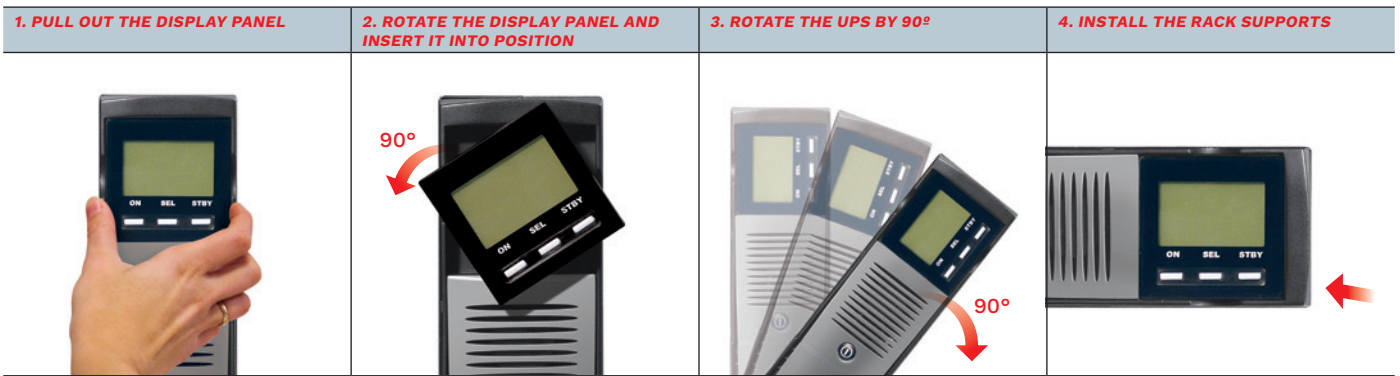

frequency switching inverter and PWM load-dependent digitally controlled fan;

- Operation guaranteed up to 40 °C (the components are designed for high temperatures and are thus subject to less stress at normal temperatures);
- On Sentinel Dual models, the output sockets can be programmed to disconnect less critical loads during blackouts (EnergyShare function).

### INSTALLATION VERSATILITY

Sentinel Dual can be used in a tower or rack format, by simply turning the display and adding the supplied handles or optional runners.

### REDUCED RUNNING COSTS

The UPS is highly flexible and easy to configure. Programmable functions can be set via software or manually via the front display panel. Sentinel Dual can be configured in the following operating modes:

- ON LINE: maximum load protection and output voltage waveform quality;
- ECO Mode: to increase efficiency (up to 98%); allows you to select LINE INTERACTIVE technology;
- SMART ACTIVE: the UPS automatically decides the operating mode based on the mains power quality;
- STANDBY OFF: the UPS can be selected to function only when the mains power supply fails (emergency only mode);
- Frequency Converter: operation (50 or 60 Hz).

### ADVANCED COMMUNICATIONS

Sentinel Dual offers maximum flexibility for integration with all types of communication systems.

- Multi-platform communication for all operating systems and network environments: PowerShield<sup>3</sup> supervision and shutdown software for Windows operating systems 10, 8, 7, Hyper-V, 2019, 2016, 2012, and previous versions,

Mac OS X, Linux, VMWare ESXi, Citrix XenServer and other Unix operating systems;

- UPS Tools configuration and customisation software supplied as standard;
- RS232 serial port and opto-isolated contacts;
- USB port;
- Slot for communications boards such as Modbus/Jbus, TCP/IP-SNMP and relay contacts.

### EMERGENCY FUNCTION

This configuration ensures the operation of emergency systems that must be supplied in the event of a mains power failure, such as emergency lighting, fire detection/extinguishing systems and alarms.

When the mains power supply fails, the inverter begins powering the loads with a progressive start up (Soft Start) in order to prevent overload.

Sentinel Dual is compliant for installation in medium-voltage transformer rooms in accordance with applicable legislation, for the power supply with reserve charge of medium-voltage coils.

### HIGH QUALITY OUTPUT VOLTAGE

- Even with non-linear loads (IT loads with a crest factor of up to 3:1);
- High short circuit current on bypass;
- High overload capacity: 150% by inverter (even with mains failure);
- Filtered, stabilised and reliable voltage (ON LINE double conversion technology (VFI compliant with EN62040-3) with filters for the suppression of atmospheric disturbances;
- Power factor correction: UPS input power factor close to 1 and sinusoidal current uptake.

### HIGH BATTERY RELIABILITY

- Automatic and manual battery test;
- Batteries are user replaceable without

switching off equipment and without interruption to the load (Hot Swap);

- Unlimited extendible runtime using matching battery cabinets.

### LOW NOISE LEVEL

Thanks to the use of high frequency components and load-based fan speed control, the noise produced by the UPS is less than 40 dB.

### OTHER FEATURES

- Output voltage can be selected via software (220/230/240 V);
- Auto-restart when mains power is restored (programmable via software);
- STANDBY ON bypass: when the machine is switched off, it automatically goes into bypass and battery charge mode;
- Minimum load switch-off;
- Battery discharge warning;
- Start up delay;
- Total microprocessor control;
- Automatic bypass without interruption;
- Status, measurements and alarms available on standard backlit display;
- UPS firmware updating via PC;
- Input protection via resettable thermal switch (versions up to 1500 VA);
- Back-feed protection standard: to prevent energy from being fed back to the network;
- Manual switching to bypass.

### 2-YEAR WARRANTY

## OPTIONS

### SOFTWARE

PowerShield<sup>3</sup>  
PowerNetGuard

### ACCESSORIES

NETMAN 204  
MULTICOM 302  
MULTICOM 352  
MULTICOM 372  
MULTICOM 384  
MULTICOM 384  
MULTICOM 384  
MULTICOM 411  
MULTI I/O  
MULTIPANEL  
Manual Bypass 16 A  
Manual Bypass 16 A Rack

### PRODUCT ACCESSORIES

Universal rails for installation in rack cabinets

## BATTERY CABINET

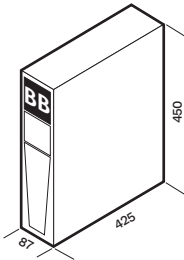
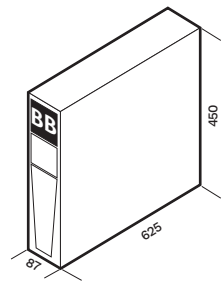
MODELS	BB SDH 36-A3 BB SDH 36-M1	BB SDH 72-A3 BB SDH 72-M1
Dimensions [mm]		

## DETAILS

### SDH 1000

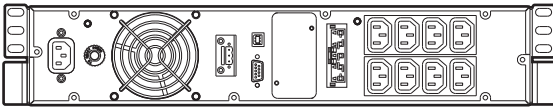

### BBX

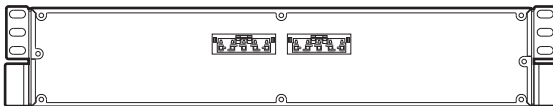

### SDH 1500

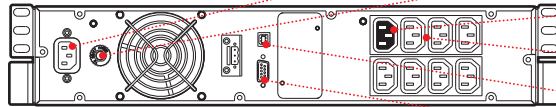

### SDH 2200/2200ER 3000/3000 ER

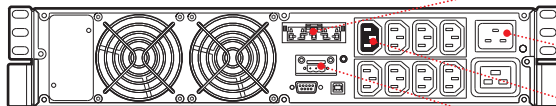

- INPUT SOCKET
- INPUT THERMAL PROTECTION
- ENERGYSHARE
- OUTPUT SOCKETS
- USB PORT
- RS232 SERIAL
- BATTERY EXPANSION SOCKET
- INPUT PLUG
- ENERGYSHARE
- COMMUNICATION PORT R.E.P.O.



MODELS	SDH 1000	SDH 1500	SDH 2200	SDH 2200 ER	SDH 3000	SDH 3000 ER
<b>POWER</b>	<b>1000 VA/900 W</b>	<b>1500 VA/1350 W</b>	<b>2200VA/1980 W</b>	<b>2200VA/1760 W</b>	<b>3000 VA/2700 W</b>	<b>3000 VA/2400 W</b>
<b>INPUT</b>						
Rated voltage [V]	220 / 230 / 240					
Voltage range without battery intervention [V]	140 <Vin <276 @ 50% load / 184 <Vin <276 @ 100% load					
Voltage tolerance [V]	230 ±20%					
Maximum permitted voltage [V]	300					
Rated frequency [Hz]	50 / 60 ±5					
Frequency tolerance [Hz]	50 ±5% / 60 ±5%					
Power factor	>0.98					
Current distortion	≤7%					
<b>BYPASS</b>						
Voltage tolerance [V]	200 / 253					
Frequency tolerance [Hz]	Frequency selected (from ±0.5 to ±5 configurable)					
Overload Times	125% for 4 sec., 150% for 0.5 sec.					
<b>OUTPUT</b>						
Voltage distortion with linear load / with non-linear load	<2% / ≤3.5%					
Frequency [Hz]	Selectable: 50 or 60 or self-learning					
Static variation	±1%					
Dynamic variation	≤5% in 20 msec.					
Waveform	Sinusoidal					
Current crest factor	3:1					
Efficiency ECO and SMART ACTIVE Modes	98%					
<b>BATTERIES</b>						
Type	VRLA AGM maintenance-free lead based					
Recharge time	2-4 h					
<b>OVERALL SPECIFICATIONS</b>						
Net weight [kg]	17.5	18	30.5	15	31	15
Gross weight [kg]	21	21.5	35	19.5	35.5	19.5
Dimensions (WxDxH) [mm]	(T- 87x425x450) (R- 19"x425x2U)			(T- 87x625x450) (R- 19"x625x2U)		
Packaging dimensions (WxDxH) [mm]	550x600x245			600x760x245		
Protection against overvoltage [J]	300					
Protections	Overcurrent - short circuit - overvoltage - undervoltage - temperature - excessive low battery					
Communications	USB / DB9 with RS232 and contacts / Slot for communications interface					
Input plugs	1 IEC 320 C14			1 IEC 320 C20		
Output sockets	8 IEC 320 C13			8 IEC 320 C13 + 1 IEC 320 C19		
Standards	European directives: L V 2014/35/EU low voltage Directive EMC 2014/30/EU electromagnetic compatibility Directive Standards: Safety IEC EN 62040-1; EMC IEC EN 62040-2; RoHS compliant Classification in accordance with IEC 62040-3 (Voltage frequency Indioendent) VFI - SS - 111					
Ambient temperature for the UPS	0 °C - +40 °C					
Recommended temperature for battery life	+20 °C - +25 °C					
Relative humidity	5-95% non-condensing					
Colour	Black					
Noise level at 1 m (ECO Mode) [dBA]	<40					
Standard equipment provided	Power cable, serial cable, USB cable, safety manual, quick start guide					

The information in this document is subject to change without notice. Riello UPS assumes no responsibility for any errors that may appear in this document. DATSDHAY20AREN